

Quality Control Sorting Machine

TQ - 18

Quality Control Sorting Machine with foreign substance reject function loading

TQ - 18GR



MODEL TQ-18

Characteristics

- *LED display
- *Ease of operation
- *Ease of maintenance
- *Space-saving design

Sorting sample

【Accepted】

【Rejected】

White rice

Brown rice

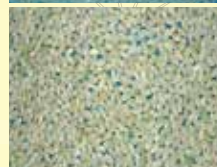

【Outline drawings】

TQ-18 · TQ-18GR

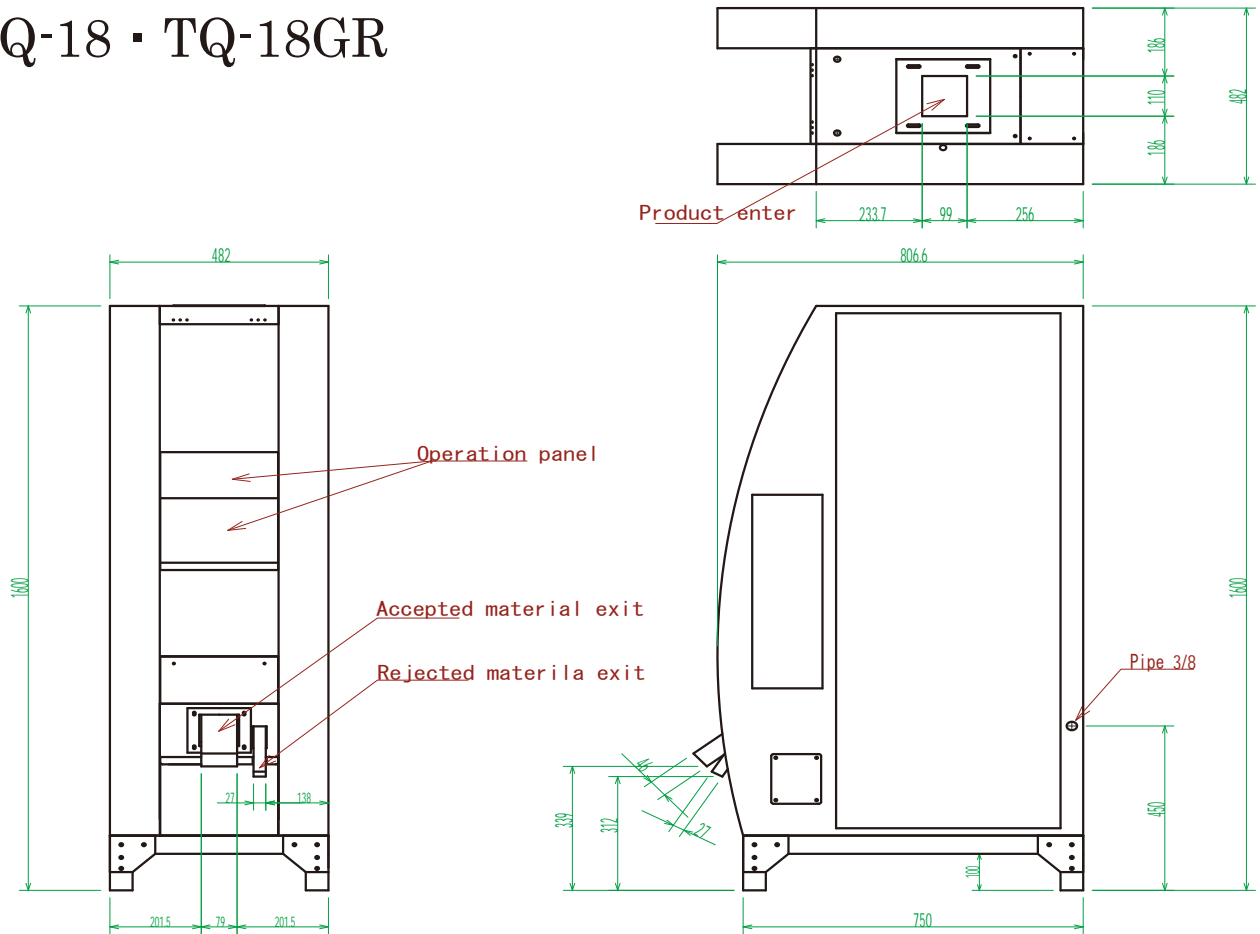

【Specification】

MODEL	TQ-18	TQ-18GR
Channel	14 Primary sorting setting	14 Primary sorting setting
	4 Secondary sorting setting	4 Secondary sorting setting
Main power	AC100V 10A	AC100V 10A
Compressor capacity	0.75kw	0.75kw
Piping (inch)	3 / 8	3 / 8
Maximum Throughput	0.8 t / h	0.8 t / h

- ※ Air compressor , air drier and dust cleaner are optional parts.
- ※ Air compressor capacity will change depends on materials.
- ※ Process capacity changes with the condition of materials and sorting.
- ※ Improvement may be made and specifications may change without notice.

Main Use

- Colored grain is sorted from cleaned rice (GR type: colored · glass · plastic · stone etc.)
- Chalky and Glutinous rice is sorted from cleaned rice (GR type: chalky · glass · plastic · stone etc.)
- Nonglutinous rice is sorted from Glutinous rice and chalky (GR type: chalky · glass · plastic · stone etc.)
- ※ Please ask dealer for details about brown rice, wheat and buckwheat.



Sales by

Active Marketing CO., LTD.

3-9-15 Minami-chou, Chuo-ku, Chiba-City

Chiba 260-0842

TEL : 043-300-7831 FAX : 043-266-1462

URL : <http://activecorp.co.jp/>